



WIRE-FREE ADD-ON CAMERA

Quick Installation Guide



Model: HGNVK-686CAM



WIRE-FREE, WORRY-FREE

Welcome
Thank you for choosing HOMEGUARD



What's in the box

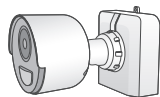

Wire-Free Camera



Rechargeable Power Pack

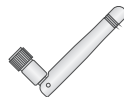

Camera Antenna



Mounting Kit

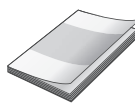

User Manual



Warning Stickers

Specifications

| Item | Description |
|------------------------|---|
| Operating System | H.264 |
| Sensor | 2.0MP, 1/2.7" COMS Sensor |
| S/N Ratio | 40 dB |
| Resolution | 2.0MP: Max. Resolution 1920×1080p |
| Audio | Two-Way Audio |
| PIR Detection Angel | 115° |
| PIR Detection Distance | 10m/33ft |
| Minimum illumination | 0.05 Lux @ F1.2 (AGC ON), 0 Lux with IR |
| Lens | 2.8mm Fixed Lens |
| White Balance | Auto |
| Noise Reduction | 3D |
| Day & Night | Auto |
| Power Supply | DC 4.2V±10% |
| Power | 1.8 W |
| Battery Capacity | 8700 mAh |
| Temperature | -10 °C ~ 55 °C |
| Humidity | 10% ~ 90% |
| Night Vision | 66ft/20m |
| Weatherproof | IP66 |

Step 1 Initial Setup

Before you begin, you will need to prepare the wire-free camera and power pack.

- 1 Peel off the **PLEASE REMOVE** label covering the contact on Power Pack. Insert the charged Power Pack into the camera base. Push up until the Power Pack 'clicks' into place.

Note: Power pack come fully charged with no need for initial charging.

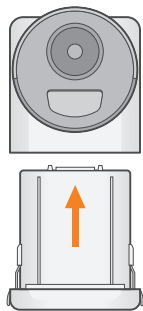

- 2 Twist the adjustment ring near the camera base counter-clockwise to loosen and reposition the camera as shown to the below. Connect the white antenna to the camera.

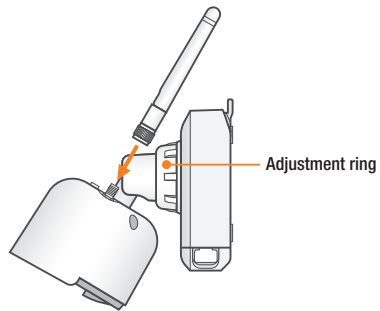

Step 2 Pairing the Camera

Pair your add-on camera to your recorder using the free **Homeguardsafe** app for smartphones and tablets (iOS and Android).

- 1 From Live view, tap any free channel you would like to pair a camera to (marked with a  icon). Tap **PAIR**. A timer for 30 seconds appears.



- 2 Press and hold the pair button on the back of the camera for 3 seconds.

Note: A "Pairing successful" message should appear on screen. If you do not see this message, repeat the steps above.



Step 3 Installing the Camera

Follow the instructions below to secure the camera. It is recommended that you refer to the “**Installation Tips**” section to help you select good mounting locations.

- 1 Set the mounting bracket in the desired mounting position. Mark holes through the mounting bracket (shown as orange X's on the below). Drill holes where marked for the mounting screws using the included drill bit (Provided in the toolkit with your wire-free system).

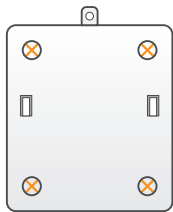

Note:

To make camera installation easier, you can adhere included bracket location stickers to the place you would like to install your cameras.

- 2 Secure the bracket to the mounting surface with the included mounting screws (x4). Make sure all screws are fastened tightly.

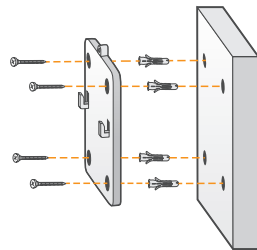

Note:

- Insert the included drywall anchors if you are mounting the camera onto drywall.
- The hole at the top of the mounting bracket will be used in step 4, once the camera is attached to the mounting plate.

- 3 Lower the camera base onto the mounting bracket so the 2 tabs in the mounting bracket lock into the 2 slots in the camera base.

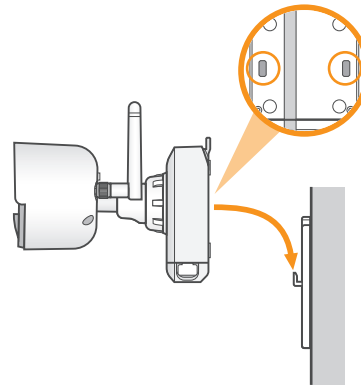

- 4 Insert the security screw through the fasteners on the top of the camera base and mounting bracket to secure the camera to the mounting bracket. Tighten using the included screwdriver (Provided in the toolkit with your wire-free system).

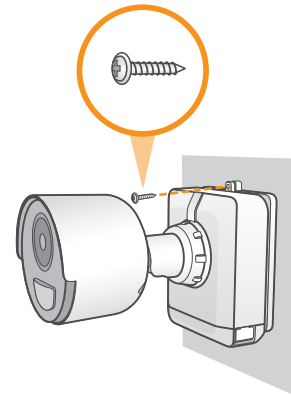

- 5 OPTIONAL:** Tighten the pre-installed locking screw on the base of the Power Pack using the included screwdriver (Provided in the toolkit with your wire-free system).

Note: You will need to loosen the locking screw to remove the Power Pack in the future.

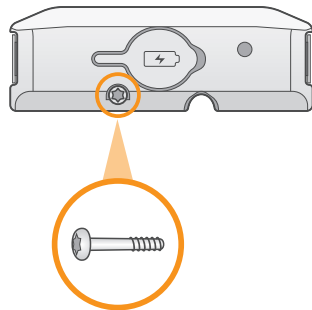

- 6** Twist the adjustment ring near the camera base counter-clockwise to loosen and reposition the camera. Hold the camera in the desired angle and tighten the adjustment ring completely to secure the camera in place.

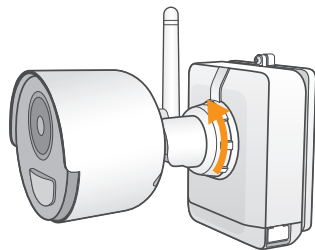

Attention: This camera includes an Auto Mechanical IR Cut Filter. When the camera changes between Day/Night viewing modes, an audible clicking noise may be heard from the camera. This clicking is normal, and indicates that the camera filter is working.

Installation Tips

The wire-free camera use a Passive InfraRed (PIR) sensor to ensure video is only recorded when motion is detected. Follow the tips below for more accurate motion detection and to optimize battery life:

- **See images to the right for ideal setup.** It is recommended to place your camera at least 7ft/2.1m above the ground and angle it slightly downward toward the monitoring area, excluding any busy areas (e.g., sidewalks or roadways).
- Ensure the camera image is free of obstructions (i.e., tree branches).
- Position the camera no more than 20ft/6.1m away from the area you wish to monitor.
- See the “Optimizing Motion Detection” section to customize motion settings for each camera on your system.
- Ensure you have configured the active area for motion detection so that only areas of interest are selected. See the “Optimizing Motion Detection” section for details.
- For best performance, position the camera so that objects of interest will move from side-to-side across the camera image, rather than moving towards or away from the camera.
- Install the camera within range of the recorder.
- This camera is weather resistant for outdoor use (IP66). Installation in a sheltered location is recommended.
- Battery life will vary based on temperature, settings and number of events.

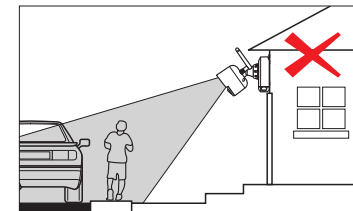
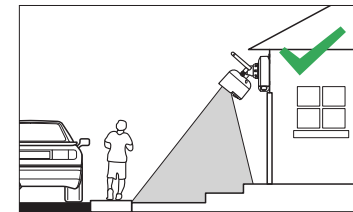

Optimizing Motion Detection

Customize motion detection settings to ensure motion events are being recorded and reduce false alarms.



1 Launch the Homeguardsafe app. Tap  → “Remote Setting”. Select a device, then tap “Motion”.

2 Configure the following as needed:

1. **Sensitivity:** The amount of motion needed to trigger recording (e.g., higher sensitivity requires less motion to trigger recording).

2. **Area Selection:** Set the active area for motion detection. Video appears with a red grid overlaid, meaning the whole image is active. Tap red squares to disable motion detection in those areas (see example image to the below). Tap Save when finished.

Tip: Disable areas that will trigger unwanted motion events, like busy streets or trees and shrubs that will move in the wind.

3. **Distance Setting:** Configure distance setting for motion detection. While watching the camera’s video on your mobile device, recreate a motion event in front of your camera. The icon will change from  to  when motion is detected by the camera. Change the distance setting if motion detection is being triggered by unwanted events.

Note: Distance will be affected by temperature.

4. **Buzzer:** Set the recorder to sound an alarm when motion is detected.

3 Tap **Save** when finished. Repeat for other cameras on the system.

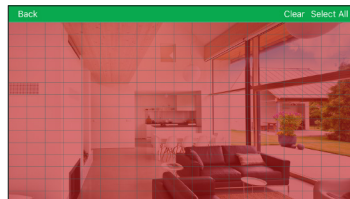
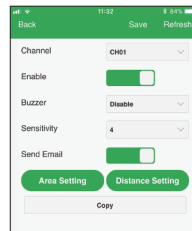

Charging the Power Pack

Use the included power adapter (Provided in the accessory with your wire-free system) to charge the power pack. Connect the power adapter to the micro USB port on the power pack. The LED indicator on the power pack shows you the charging status (must be plugged in).

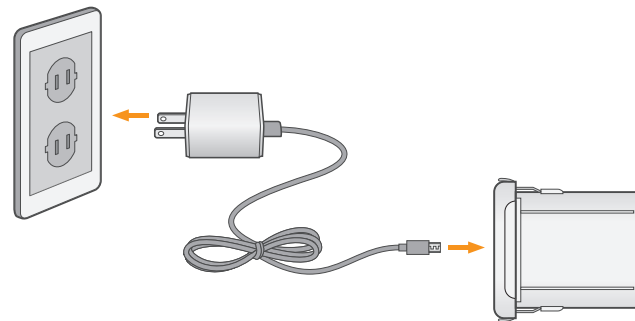

| Power Pack | Charge Time |
|------------|-----------------|
| 2-cell | Approx. 6 hours |
| 3-cell | Approx. 8 hours |

| LED Color | Meaning |
|-----------|--------------------|
| ● Green | Fully charged |
| ● Red | Currently charging |

Note:

The Power Pack LED flashes red while outside the safe charging temperature of 32-113°F (0-45°C). In this state, the camera remains powered up, but the Power Pack will not charge outside the safe temperature range.

Warranty & Support

All the products sold are covered by 24 months warranty from the date of invoice.

Warranty instructions:

1. Please contact us when the product is caused by its own fault within 2 year warranty.
2. Please mail us your written warranty card as soon as possible after purchasing our products so that we can repair or replace this product to its original operation condition. Or the company will not deal with it.
3. Please write the truth on the warranty card.
4. Paid for repairing as follows:
 - A. Equipment failure caused by human operation
 - B. Equipment failure caused by not conforming to the using environment
 - C. No warranty card
 - D. Warranty expired

Product model: _____

Product serial number: _____

Purchase date: _____

User name: _____

Contact person: _____

Telephone: _____



Note: Please keep the warranty card for the better service.
For technical support, please contact us support@homeguardworld.com or <https://helpdesk.intelek.cz>

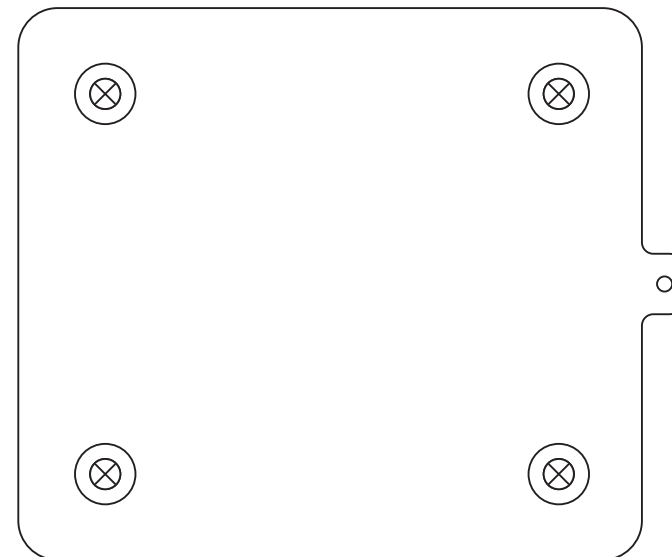

This template is used to install the camera on the wall